

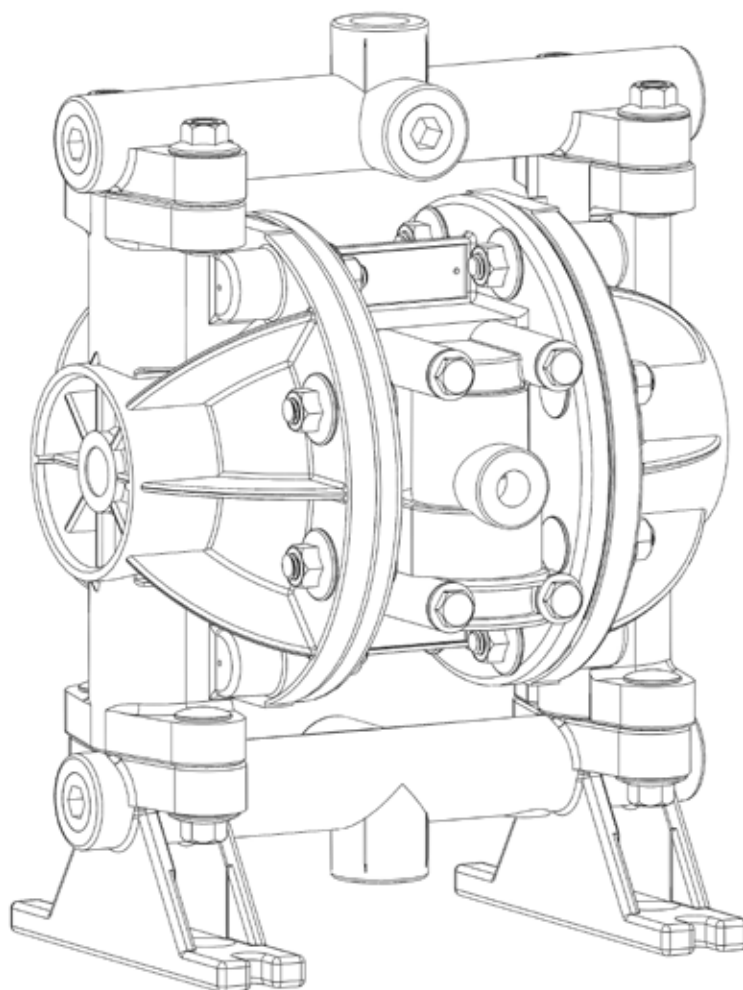

PUMP-FIT MODEL SERIES PF66605

Assembly, Installation and Operation Manual





EU Declaration of Conformity



Pump-Fit hereby declares that the following machine(s) fully comply with the applicable health and safety requirements as specified by the EU Directives listed. The complete product complies with the provisions of the EU Directive on machinery safety.

This declaration is valid provided that the devices are fully assembled and no modifications are made to these devices.

Type of Device:

Air Operated Double Diaphragm Pumps

Models:

PF66605J-3EB

PF66605J-344

EU Directives:

Machinery Safety (2006/42/EC)

Applied Harmonized Standards:

EN ISO 12100

Manufacturer:

Pump-Fit

921 Greengarden Road

Erie, Pennsylvania 16501-1591 U.S.A

Signed,

President

3 February 2016

Person(s) Authorized to Compile Technical File: Pump-Fit GmbH
Otto-Hahn-Strasse 16
Maintal, D-63477 DEU
Telephone: 49 (0)6181-90878-0

Table of Contents

Important Information - Read Me First	
Chemical Reaction Disclaimer.....	4
Safety Precautions	4
Part Number Explanation.....	5
Pump Data.....	5
Installation & Operation Precautions	5
Section I - Maintenance	6
Section II - Disassembly / Reassembly Fluid Section.....	6
Section III - Disassembly/Reassembly Pilot Valve	7
Section IV - Disassembly/Reassembly Major Valve.....	7
Section V - Troubleshooting	8
Section VI - Warranty.....	8
Spare Parts Diagram	10
Spare Parts List.....	11-12
Dimensional Drawing	13

Pump-Fit Contacts:

Headquarters (USA)

Tech Service: PH: 800-888-3743;

Email: techservice@finishthompson.com

Order Fax: 814-459-3460 or 814-455-8518

Sales: 1-814-455-4478; Toll Free 1-800-934-9384 (U.S. & Canada)

Europe Center (Germany)

Tech Service: PH: +49 (0)6181-90878-0

Email: europcenter@finishthompson.com

Order Fax: +49 (0)6181-90878-18

Sales: +49 (0)6181-90878-0

IMPORTANT INFORMATION-READ ME FIRST!

Model Number and Serial Number

Record the model number and serial number below for future reference. This is important information when ordering replacement parts or when technical assistance is required. The numbers are found on a label located on the pump body next to the air valve.

MODEL NUMBER = _____

SERIAL NUMBER = _____

Chemical Reaction Disclaimer

The user must exercise primary responsibility in selecting the product's materials of construction, which are compatible with the fluid(s) that come(s) in contact with the product. The user may consult Pump-Fit (manufacturer) and a manufacturer's representative/distributor agent to seek a recommendation of the product's material of construction that offers the optimum available chemical compatibility.

However neither manufacturer nor agent shall be liable for product damage or failure, injuries, or any other damage or loss arising out of a reaction, interaction or any chemical effect that occurs between the materials of the product's construction and fluids that come into contact with the product's components .

Safety Precautions

⚠ WARNING: READ THIS MANUAL COMPLETELY BEFORE INSTALLING AND OPERATING THIS PUMP. FAILURE TO FOLLOW THESE PRECAUTIONS CAN RESULT IN SERIOUS INJURY OR DEATH.

⚠ WARNING PF66605J-3EB & PF66605J-344 model pumps are not intended to pump flammable or combustible materials (consult factory).

⚠ WARNING Do not exceed maximum pressure stated on the pump serial number sticker. Pump exhaust may be loud and contain particles. Wear appropriate ear and eye protection. In the event of a diaphragm rupture material can be forced out of the air exhaust muffler. If product is hazardous or toxic pipe exhaust to appropriate safe area.

⚠ WARNING: Chemical Hazard. This pump is used for transferring many types of potentially dangerous chemicals. Always wear protective clothing, eye protection and follow standard safety procedures when handling corrosive or personally harmful materials. Proper procedures should be followed for draining and decontaminating the pump before disassembly and inspection of the pump. There may be small quantities of chemicals present during inspection.

⚠ WARNING Before maintenance or repair, close the compressed air supply valve, bleed the pressure and disconnect air line from the pump. Discharge line may be pressurized. Any pressure must be relieved before service.

CAUTION Do not use the pump as the support for the piping system. System components must be properly supported to prevent stress on the pump parts.

Suction and discharge connections should be flexible connections (such as hose), not rigid piped, and must be compatible with the substance being pumped and system pressure.

CAUTION To help avoid unnecessary damage to the pump, do not allow pump to run dry for long periods of time.

CAUTION Use only genuine Pump-Fit replacement parts to assure compatible pressure rating and longest service life.

CAUTION If pump is used with materials that tend to solidify or settle pump should be flushed after each use to prevent damage.

NOTICE Install the pump in a vertical position or the pump may not prime properly.

NOTICE Re-torque all fasteners before operation. Creep of housing and gasket materials may cause fasteners to loosen. Re-torque all fasteners to insure against fluid or air leakage.

NOTICE Unpack the pump and examine for any signs of shipping damage. If damage is detected, save the packaging and notify the carrier immediately.

Part Number Explanation

Part Number Model Codes				
PF66605J-3EB & PF66605J-344				
Model	Fluid Cap & Manifold	Seat Material	Ball Material	Diaphragm Material
PF66605	J	3	E	B
PF66605	J	3	4	4
	(J-Polypropylene)	(3-Polypropylene)	(E-Santoprene)	(B-Santoprene)
			(4-PTFE)	(4-PTFE/Santoprene)

Pump Data	
Pump Type: Non-Metallic Air Operated Double Diaphragm	
Weight: 6.5 lbs / 2.95 kgs	Max Flow Rate: 13 GPM (49.2 lpm)
Air Inlet Size: 1/4" FNPT	Suction / Discharge Size: 1/2" FNPT /FBSP
Max Air Inlet Pressure: 100 psig (6.9 bar)	Max Particle Size: 3/32" (2.4mm)
Max Material Inlet Pressure: 10 psig (.69 bar)	Max outlet Pressure: 100 psig (6.9 bar)
Air Consumption: 1 cfm / gallon	Displacement Per Stroke: .040 gal. (.15 lit.)
Maximum Temperature Limits for Elastomers, Balls Seats & Diaphragms:	
Polypropylene: 35° to 175° F (2° to 79° C)	
Santoprene: -40° to 225° F (-40° to 107° C)	
PTFE: 40° to 225° F (4° to 107° C)	
Maximum Noise Level: 67 dB (A)	

Installation / Operation Precautions

Installation

Pump should be located as close to the fluid supply as possible. Keep the suction line length short & fittings to a minimum. Use a minimum of ½" suction line diameter. When using rigid pipe run short sections of flexible hose between the pump & piping. Secure the pump base to a suitable surface.

Operation

The Pump-Fit PF66605 Models diaphragm pumps are a 1:1 ratio design and will provide up to 13 GPM (49.2 lpm) of flow and up to 100 psi of discharge pressure.

Ball checks ensure a positive flow of fluid. Pump will start cycling as air pressure is applied. Pump will build and maintain line pressure and will stop cycling once maximum line pressure is reached or discharge is closed. Pump will resume pumping when line pressure drops or discharge valve is reopened.

If pumping materials that are subject to crystallizing, always flush the pump with a non-flammable fluid compatible with the pump's materials of construction.

The flow rate is controlled not only by the air supply but also by the fluid being pumped. Fluid viscosity will reduce the obtainable flow rate. Use a minimum of a ½" discharge line diameter to reduce friction losses. Be sure to use vacuum rated hose on the suction side.

Section I – Maintenance

Inspect and replace worn parts with new parts as necessary. Look for damage on metallic surfaces, nicks or cuts on seals & o-rings. Recommended tools: 7/16” wrench, 1/2” wrench, 7/16” socket, 1/2” socket, torque wrench, o-ring pick, 3/8” allen wrench & snap ring pliers.

Section II – Disassembly / Reassembly Fluid Section

FLUID SECTION DISASSEMBLY

1. Remove 4 flange nuts (item 15) and lift the discharge manifold (item 14) off of the motor body (item 17).
2. Remove the ball cages (item 12), balls (item 10), o-rings (items 7 and 8) and seats (item 9) from the fluid cap (item 6).
3. Invert the pump & set it on the discharge manifold bolts (item 11). Remove the 4 suction manifold flange nuts (item 15) and suction manifold (item 13).
4. Remove the ball cages (item 12), balls (item 10), o-rings (item 7) and seats (item 9) from the fluid caps (item 6).
5. Stand the motor body (item 17) on the suction or discharge manifold bolts (item 11) and remove the 8 flange nuts (item 15) from both fluid caps (item 6). Pull the fluid caps (item 6) away from the motor body (17). Note: If ball cages (item 12) balls (item 10), o-rings (items 7 and 8) and seats (item 9) were not removed in step 2 or 4 they can be removed now by accessing them from the inside of the fluid caps (item 6).
6. Remove diaphragm plate (item 4), diaphragm(s) (item 5 or 5A) and diaphragm plate (item 3) from diaphragm connecting rod (item 1).
7. Remove connecting rod (item 1) from air motor (item 17) by pulling on the remaining diaphragm. Rod should pull out easily from the motor body.
8. Carefully remove remaining diaphragm plate (item 4), diaphragm(s) (item 5 or 5A) and diaphragm plate (item 3) from diaphragm connecting rod (item 1). Be careful not to damage the surface of the connecting rod.
9. Remove o-ring (item 2) from connecting rod (item 1).

FLUID SECTION REASSEMBLY

1. Lubricate connecting rod (item 1) and o-ring (item 2) with white lithium grease or equivalent o-ring lubricant and push into motor body (item 17).
2. Reinstall diaphragm plates (items 3 & 4) with chamfer toward diaphragms.
3. Reinstall diaphragms. When replacing PTFE diaphragms first install the Santoprene backer diaphragm behind the PTFE diaphragm. Refer to diaphragm figure (right) for proper placement. Make sure holes in the diaphragms align with the bolts (item 29) from the motor body (item 17). It's recommended to install the 8 fluid cap bolts (item 29) at this point to hold the PTFE diaphragms in place. Once both sides have been installed hold one nut with a wrench while tightening the other with the torque wrench. Tighten to: 95 - 105 in. lbs (10.7 - 11.9 Nm). Reinstall Fluid caps (item 6) onto motor body (item 17) with flange nuts (item 15) alternately and evenly, and tighten to: 50 - 60 in. lbs (5.6 - 6.8 Nm) then retorque after initial run-in.
4. Make sure the ball guides line up with the notches in seat (item 9) when reinstalling ball cage (item 12) into fluid caps (item 6).
5. Make sure that o-rings (item 7) are in their proper position on the o.d. of ball cage (item 12) before reinstalling manifolds (item 14) & (item 13). Reinstall flange nuts (item 15) alternately and evenly, and tighten to: 50 - 60 in. lbs (5.6 - 6.8 Nm) then re-torque after initial run-in.
6. If plugs (item 16) are removed reinstall them using an allen wrench and tighten to: 25 in. lbs (2.8 Nm) maximum.

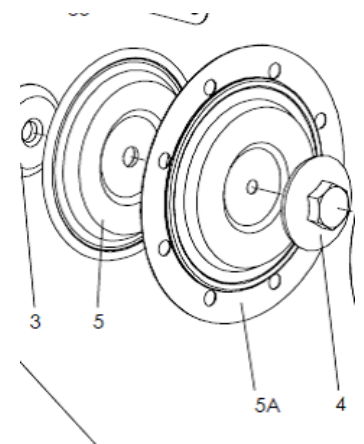

Section III – Disassembly / Reassembly – Pilot Valve

PILOT VALVE DISASSEMBLY

1. To disassemble the pilot valve first remove snap rings (item 25) and (item 20) with a snap ring pliers.
2. Now remove plates (item 41), sleeve (item 19) and o-rings (item 18).
3. Remove, pilot rod (item 22) with washers (item 40), o-rings (item 23) and spacers (item 24) from motor body (item 17).

PILOT VALVE REASSEMBLY

1. Assemble o-rings (item 23), spacers (item 24) and washers (item 40) on pilot rod (item 22). Important: These items must be installed in the proper order for the valve to work properly. Refer to the exploded view drawing for correct sequence. Lubricate all o-rings with white lithium grease or equivalent o-ring lubricant.
2. Insert the assembly into the motor body (item 17). Sleeve (item 19) may be used to assist pressing stack into body.
3. Reinstall sleeve (item 19) and o-rings (item 18) into motor body (item 17). Lubricate all o-rings with white lithium grease or equivalent o-ring lubricant.
4. Reinstall plates (item 41) and snap rings (item 25) and (item 20).

Section IV – Disassembly / Reassembly – Major Valve

MAJOR VALVE DISASSEMBLY

1. Loosen & remove valve block washers & bolts (items 31 & 32). This will allow the exhaust cover and gasket (items 27 & 28) to be removed from the back side of the pump.
2. Pull valve block assembly (item 33) from motor body (item 17) along with bolts, washers and gasket (items 30, 31 & 32).
3. Pull the gasket (item 30) from the valve block (item 33) along with the valve plate (item 39) and valve insert (item 38). Caution should be taken not to drop & break the ceramic valve plate (item 39) and valve insert (item 38).
4. To remove the spool (item 21), first remove the plug (item 34). It may be necessary to use the spool while it is still in the valve body and push it downward to expose the plug and allow it to be pulled from the valve block. Once the plug (item 34) has been removed the spool (item 24) can be removed.

MAJOR VALVE REASSEMBLY

1. Prior to reinstalling the spool (item 21) it is recommended to replace the u-cups (items 36 & 37). **Important:** Open end of u-cups must face each other. See diagram below.

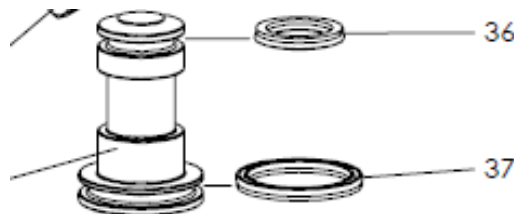

2. Reinsert spool (item 21) into the valve block (item 33) and reinstall the plug (item 34) to hold it in place. Prior to reinstalling the plug replace the o-ring (item 35).
3. Reinstall the valve insert (item 38) and valve plate (item 39) into valve block (item 33). Important: Valve insert & valve plate (items 38 & 39) are white (ceramic), the pocket side of the valve insert (item 38) should be against the polished face of valve plate (item 39) to work properly.
5. Replace gasket (item 30) and install valve block assembly (item 33) on motor body (item 17). Reinstall washers & bolts (items 31 & 32). Tighten to: 15 - 20 in. lbs (1.7 - 2.3 Nm), wait 15 minutes, then re-torque.

Section V - Troubleshooting

If pumped material is coming out of the pump's air exhaust.

- Check for ruptured diaphragms (item 5 or 5A).
- Check proper torque of diaphragm nuts (item 4).

If air bubbles are present in the Pumps discharge line.

- Check all suction plumbing connections.
- Check all o-rings from the intake manifolds (items 13 & 14) to the fluid caps (item 6).
- Check proper torque of diaphragm nuts (item 4).

If low flow.

- Check air pressure & cfm.
- Check for restrictions in the suction or discharge hose / piping.
- Is the pump priming properly? Make sure pump is mounted in the vertical position.
- Is the pump cavitating? Suction pipe should be 1/2" minimum or larger.
- Suction hose must be vacuum rated.
- Check all o-rings from the intake manifolds (items 13 & 14) to the fluid caps (item 6).
- Check to make sure balls (item 10) are seating properly with seats (item 9).
- If cycling or erratic performance occurs replace o-rings (item 23) on pilot rod (item 22).

If Pump Stalls and air blows air out exhaust.

- Check u-cups on (item 24) spool for wear or damage and replace.
- Check valve plate and insert (items 38 & 39) for wear or damage and replace.
- Check sleeve and o-ring (items 19 & 2) on diaphragm rod for wear or damage and replace.
- Check o-rings (item 23) on (item 22) pilot rod for wear or damage and replace.

Phone Pump-Fit's Technical Service Department at 1-800-888-3743 or e-mail techservice@finishthompson.com if you have any questions regarding product operation or repair.

Section VI - Warranty

Pump-Fit (manufacturer) warrants this pump product to be free of defects in materials and workmanship for a period of two years from date of purchase by original purchaser. If a warranted defect, which is determined by manufacturer's inspection, occurs within this period, it will be repaired or replaced at the manufacturer's option, provided (1) the product is submitted with proof of purchase date and (2) transportation charges are prepaid to the manufacturer. Liability under this warranty is expressly limited to repairing or replacing the product or parts thereof and is in lieu of any other warranties, either expressed or implied. This warranty does not apply to normal wear of the product or components. This warranty does not apply to products or parts broken due to, in whole or in part, accident, overload, abuse, chemical attack, tampering, or alteration. The warranty does not apply to any other equipment used or purchased in combination with this product. The manufacturer accepts no responsibility for product damage or personal injuries sustained when the product is modified in any way. If this warranty does not apply, the purchaser shall bear all cost for labor, material and transportation.

Manufacturer shall not be liable for incidental or consequential damages including, but not limited to, process down time, transportation costs, costs associated with replacement or substitution products, labor costs, product installation or removal costs, or loss of profit. In any and all events, manufacturer's liability shall not exceed the purchase price of the product and/or accessories.

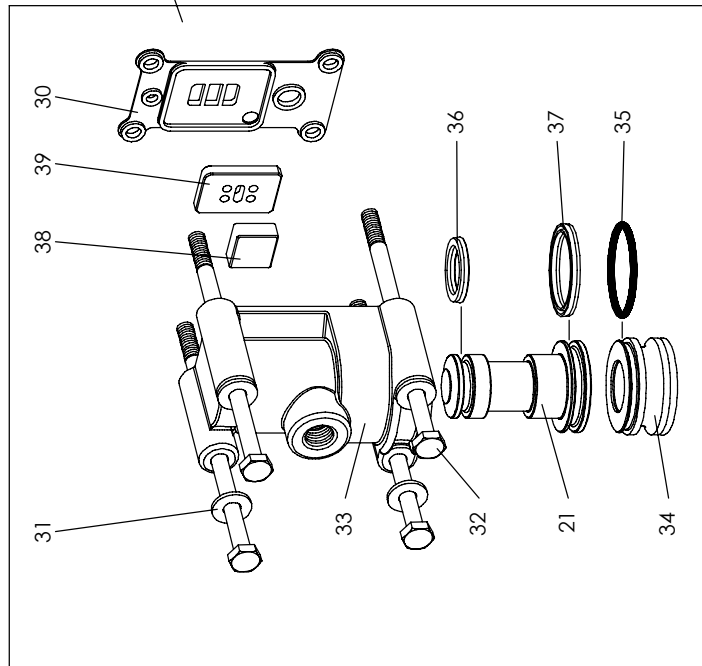
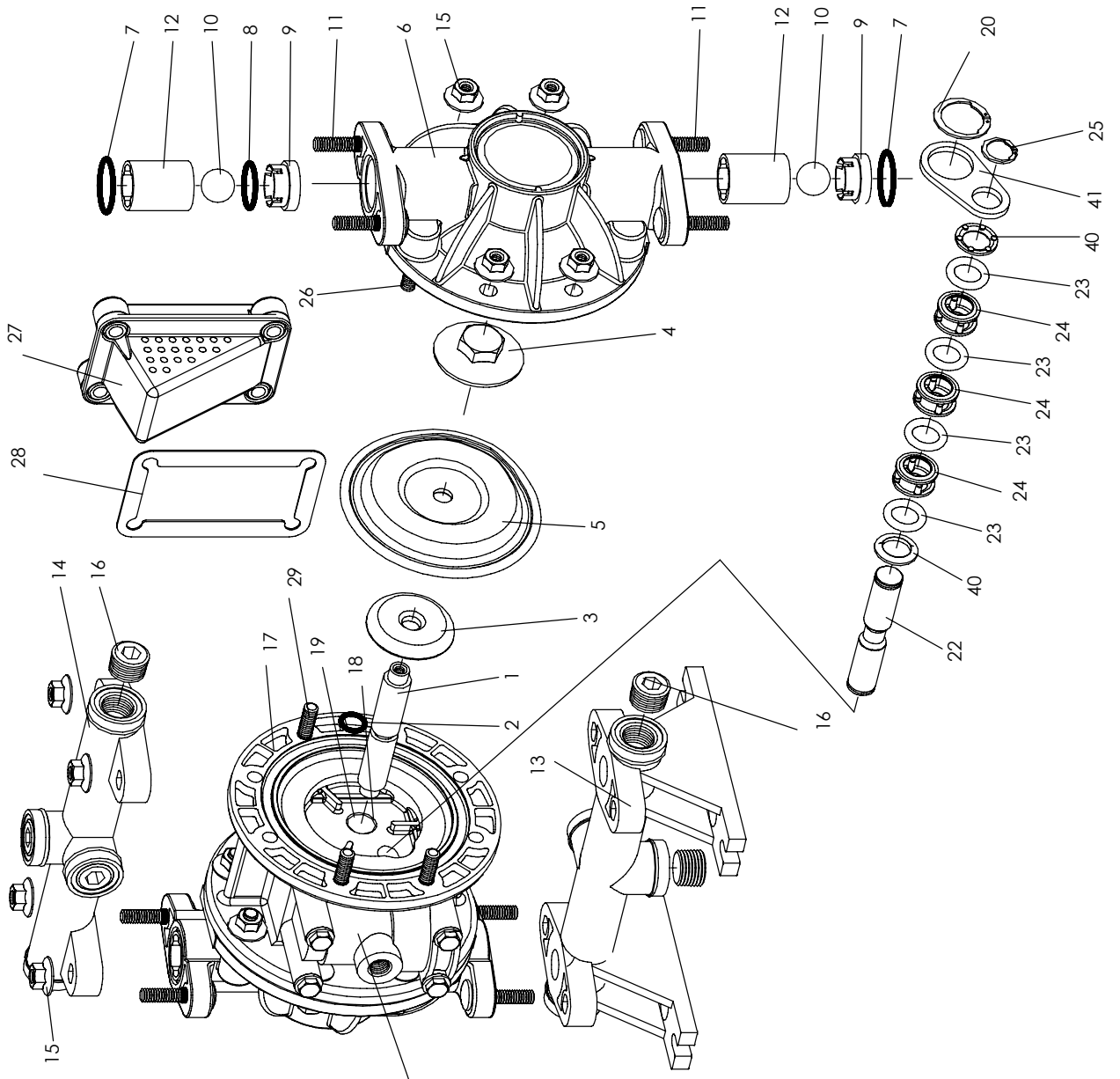

PF66605 Model Spare Parts

Item	Description	Qty	Part Number	Material Code
1	Rod	1	PF93084	[SS]
2	O-Ring (3/32" x 5/8" OD)	1	PFY325-111	[B]
3	Diaphragm Plate (2" OD)	2	PF94645	[GFN]
4	Diaphragm Plate (5/16"-18)	2	PF93103-1	[P]
5	Diaphragm	2	PF93465	[Sp]
5A	Diaphragm (also requires PF93465)	2	PF93111	[T]
6	Fluid Cap (includes 11 & 26)	2	PF93105-1	[P]
7	O- Ring (1-5/16" OD)	4	PF93763	[E]
	O- Ring (1-5/16" OD)	4	PF93265	[T]
8	O- Ring (1-1/8" OD)	2	PF93761	[E]
	O- Ring (1-1/8" OD)	2	PFY328-119	[T]
9	Seat	4	PF93098-1	[P]
	Seat (required for PTFE balls)	4	PF93098-10	[P]
10	Ball	4	PF93100-E	[Sp]
	Ball	4	PF93100-4	[T]
11	Bolt (5/16"-18 x 1-1/2")	8	PF93109	[SS]
12	Ball Cage	4	PF93097-1	[P]
13	Manifold, suction (bottom)	1	PF93802-1	[P]
14	Manifold, discharge (top)	1	PF93801-1	[P]
15	Flange Nut (5/16"-18)	24	PF93886	[SS]
16	Plug (1/2-14 MNPT)	6	PF93897-1	[P]
17	Motor Body	1	PF93091	[P]
18	O-Ring (3/32" x 1" OD)	2	PFY325-117	[B]
19	Sleeve	1	PF93087	[Bz]
20	Snap-Ring (13/16")	2	PF37285	[C]
21	Spool	1	PF93085	[D]
22	Pilot Rod	1	PF93088	[C]
23	O-Ring (1/8" x 3/4" OD)	4	PF93075	[U]
24	Spacer	3	PF115959	[Z]
25	Snap-Ring (1/2")	2	PF77802	[C]
26	Stud (5/16"-18 x 1-17/32")	8	PF93249	[SS]
27	Muffler Assembly	1	PF66972	[P]
28	Gasket	1	PF93107	[SY]
29	Bolt (5/16"-18 x 1-1/4")	8	PF93095	[SS]
30	Gasket	1	PF93339-1	[B]
31	Washer(9/32" ID)	4	PF93096	[SS]
32	Bolt (1/4"-20 x 5")	4	PFY6-419-T	[SS]
33	Valve Block	1	PF93090	[P]

Item	Description	Qty	Part Number	Material Code
34	Plug	1	PF93086	[D]
35	O-Ring (3/32" x 1-1/2" OD)	1	PFY325-125	[B]
36	U-Cup (1/8" x 1" OD)	1	PF94395	[U]
37	U-Cup (1/8" x 1.427" OD)	1	PF96383	[U]
38	Valve Insert	1	PF93276	[CK]
39	Valve Plate	1	PF93275	[CK]
40	Washer	2	PF116038	[Z]
41	Plate	2	PF93089	[SS]
-	White Lithium Grease	1	110100	-
-	Service Kit-Santoprene - Includes items: 5, 7, 8 & 10	1	PF637140-EB	[Sp,E]
-	Service Kit-PTFE-Includes item: 5, 5A, 7, 8 & 10	1	PF637140-44	[T,Sp]
-	Service Kit-Air Valve- Includes items: 18, 23, 25, 28, 30, 35, 36, 37, 38 & 39	1	PF637141	[B,U,C,SY,CK]

Mat'l Codes: **SS**=Stainless Steel, **B**=Nitrile, **GFN**=Glass Filled Nylon, **P**=Polypropylene, **Sp**=Santoprene, **E**=E.P.R., **Bz**=Bronze, **C**=Carbon Steel, **D**=Acetal, **U**=Polyurethane, **Z**=Zinc, **SY**=Syn-Seal, **CK**=Ceramic.

Ordering Spare Parts

Spare parts can be ordered from your local Pump-Fit distributor. For a list of Pump-Fit distributors go to <http://www.pumpfit.net/>.

Always refer to the pump model to avoid ordering incorrect parts.

Other PUMP-FIT Products

See our full product range at <http://www.pumpfit.net/>.

OUTLINE DIMENSIONS

DIMENSIONS SHOWN ARE FOR REFERENCE ONLY

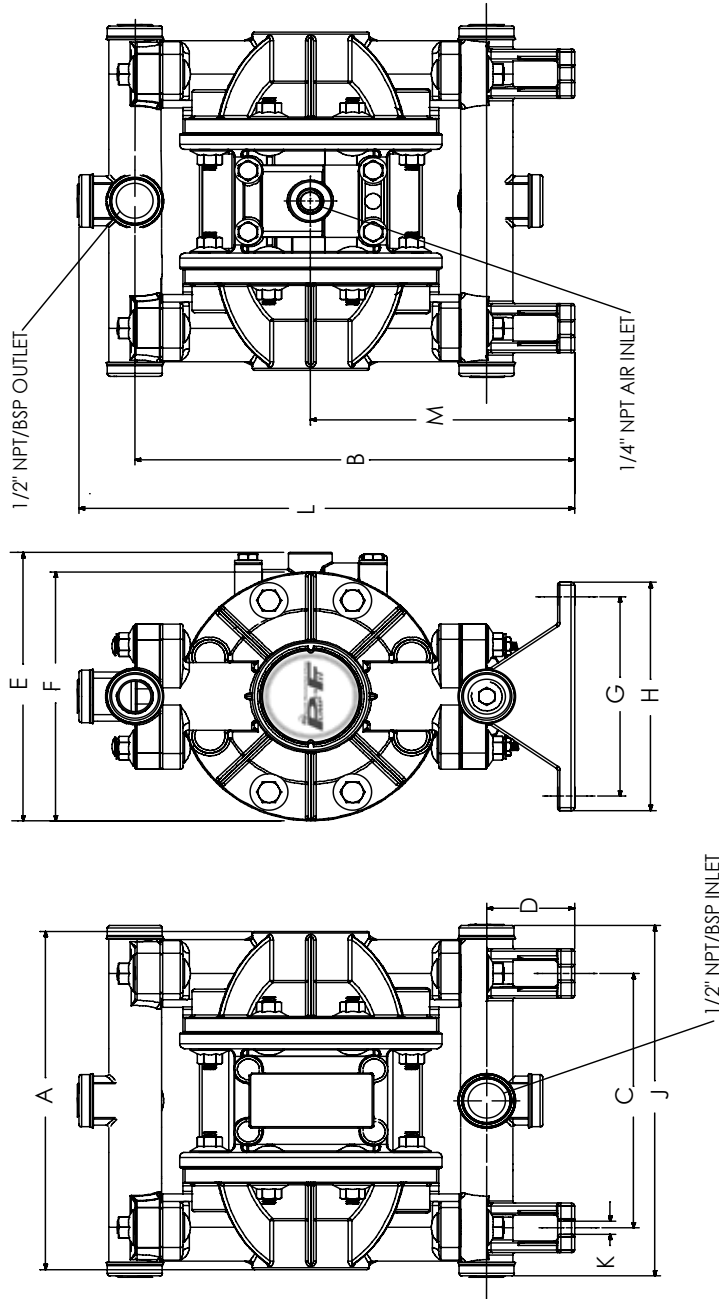

DIMENSIONS

A - 8.16" (207 mm)	E - 6.47" (164 mm)	J - 8.45" (215 mm)
B - 10.05" (255 mm)	F - 6.00" (152 mm)	K - 0.31" (8 mm)
C - 6.14" (156 mm)	G - 4.81" (122 mm)	L - 11.33" (288 mm)
D - 2.01" (51 mm)	H - 5.50" (140 mm)	M - 6.04" (153 mm)