

KC Series

MAGNETIC SEALLESS PUMPS

KC11 Sealless Centrifugal Pumps

1.0 to 3.0 Hp
(.55 to 2.2 kW)



KC11 PP



KC11 PVDF

Features

- 24-hour run-dry capability with carbon bushing
- Polypropylene or PVDF
- Excellent chemical resistance
- Mounts to standard NEMA 56C, 145TC or IEC 80 or 90 frame motors with B14
- NPT or BSP threads
- Rugged cantilevered ceramic spindle
- Back pull-out design for easy service
- 1.8 specific gravity
- 50 cps maximum

NISUS (THAILAND) CO., LTD.

Tel : 0-2898-8901-3 , Fax : 0-2898-7745

www.nisusthailand.co.th

www.nisusthailand.com

E-mail : info@nisusthailand.co.th

Performance

60 Hz 3450 rpm

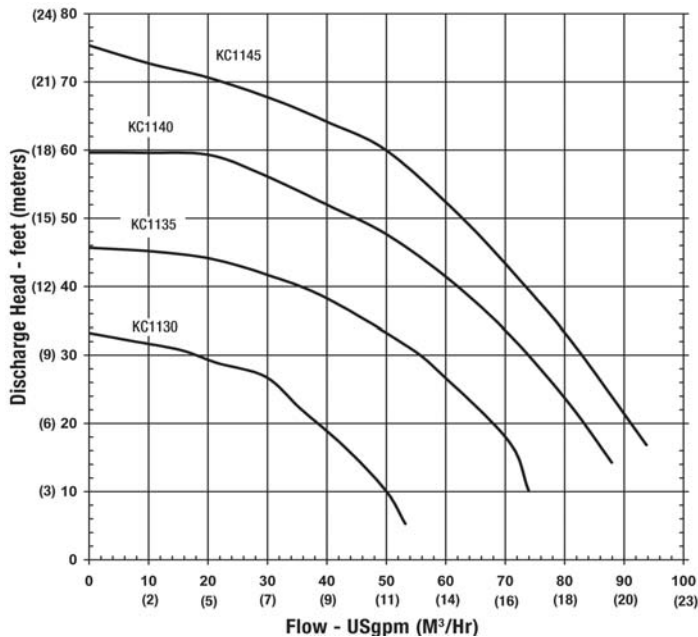

50 Hz 2900 rpm

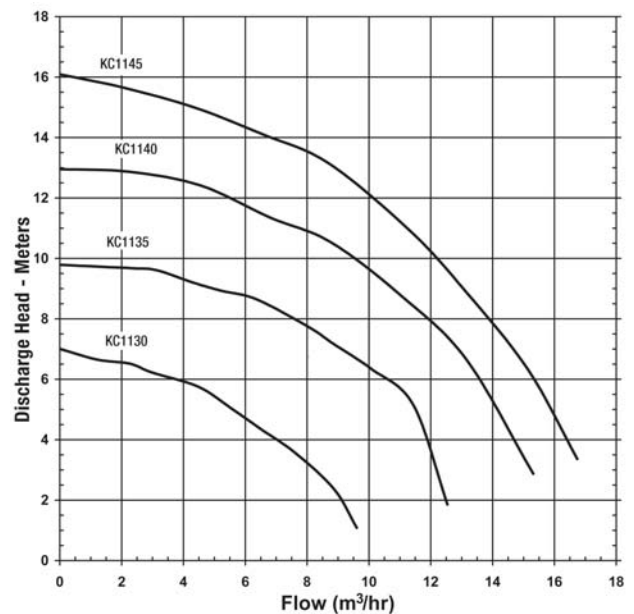

Specifications

MODEL (CONSTRUCTION)	SUCTION DISCHARGE	IMPELLER SIZE		MAX. FLOW			MAX. HEAD			MOTOR DRIVE	
		inch	cm	3450 rpm		2900 rpm	3450 rpm		2900 rpm	3450 rpm	2900 rpm
				gpm	m ³ /hr	m ³ /hr	ft	m	m	hp	kW
KC1130	1-1/2" FNPT 1-1/4" MNPT	3.0	7.6	53	12	9.6	33	10	7.0	1.0 - 1.5	.55 - .75
KC1135		3.5	8.9	74	17	12.5	46	14	9.8	1.5 - 2.0	.75 - 1.1
KC1140		4.0	10.2	88	20	15.3	60	18	13.0	1.5 - 3.0	.75 - 2.2
KC1145		4.5	11.4	94	21	16.7	75	23	16.1	2.0 - 3.0	1.1 - 2.2

P - Polypropylene glass filled, carbon, PTFE, high purity ceramic and Viton®. Maximum temperature 180°F (82°C).

V - PVDF carbon filled, carbon, PTFE, high purity ceramic and Viton. Maximum temperature 220°F (104°C).

NOTE: (1) Actual performance may vary. Pump models and performance vary with conditions.

(2) Maximum working pressure: 35 psi - polypropylene construction, 45 psi - PVDF construction

NISUS (THAILAND) CO., LTD.

Tel : 0-2898-8901-3 , Fax : 0-2898-7745

www.nisusthailand.co.th

www.nisusthailand.com

E-mail : info@nisusthailand.co.th

*Viton is a registered trademark of DuPont Dow Elastomers.

Dimensions

Close Coupled

Pedestal Mounted

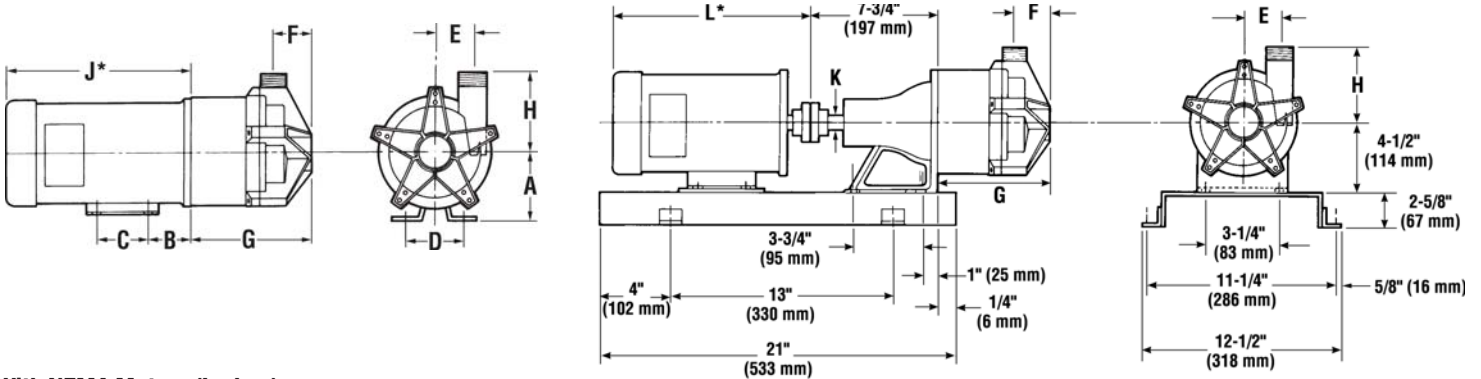

With NEMA Motors (Inches)

MODEL	MOTOR FRAME	A	B	C	D	E	F	G	H	J*	K	L*
KC11	56C	3-1/2	2-3/4	3	4-7/8	2-1/4	2-3/8	7-1/2	4-3/4	12-1/8	3/4	14
	145TC			5	5-1/2							15

With IEC Motors (Millimeters)

MODEL	MOTOR FRAME	A	B	C	D	E	F	G	H	J*	K	L*
KC11	80	80	50	100	125	57	60	191	121	230	19	268
	90	90	56	125	140					250		312

* Varies by manufacturer



FINISH THOMPSON INC.

921 Greengarden Road • Erie, PA 16501-1591 U.S.A.

Ph 814-455-4478 • Fax 814-455-8518

Email fti@finishthompson.com • www.finishthompson.com

Toll Free USA & Canada 1-800-934-9384

Literature I.D. No. FT98-705D, 4-05



AN ISO 9001 COMPANY