

SIGN HERE

FINISH THOMPSON INC.

NISUS (THAILAND) CO., LTD.
 Tel : 0-2898-8901-3 , Fax : 0-2898-7745
 www.nisusthailand.co.th
 www.nisusthailand.com
 E-mail : info@nisusthailand.co.th

DB Series: Model DB22

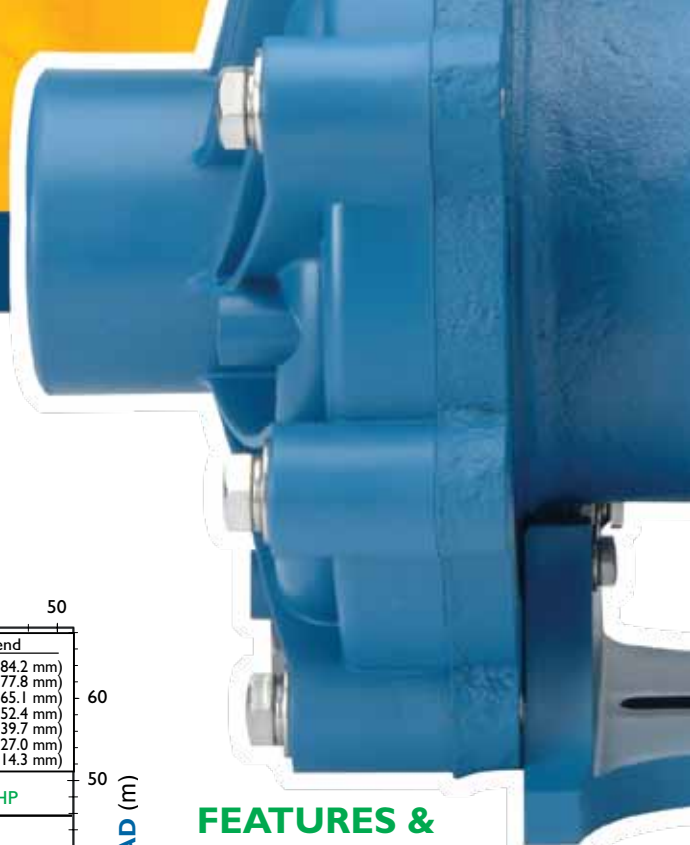

DB22 PERFORMANCE - 3450 RPM

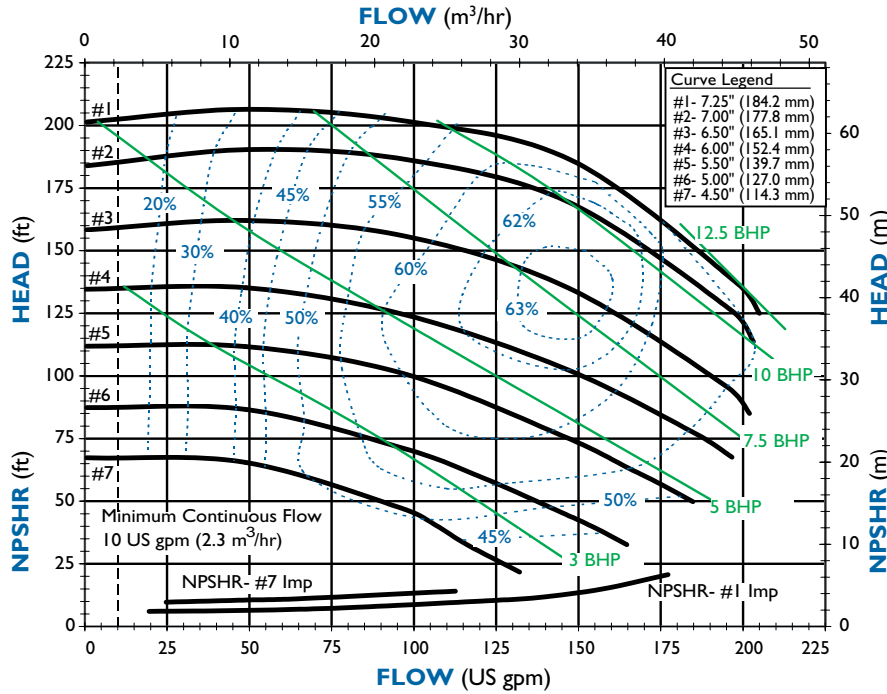

DB22 PERFORMANCE - 2900 RPM

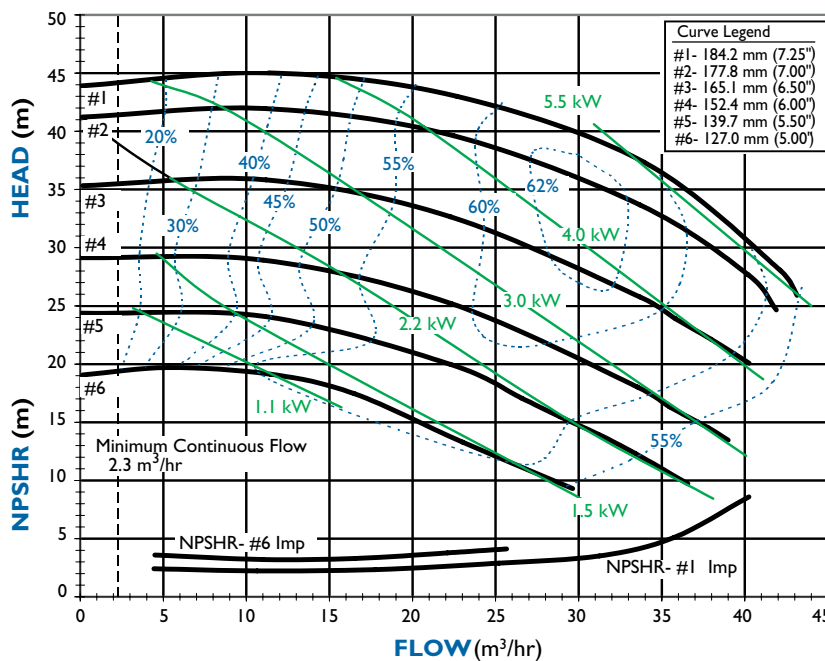

FEATURES & CAPABILITIES

- + Extended run dry ability (with carbon bushing)
- + High operating efficiency
- + Easy set, measurement-free drive
- + Polypropylene or PVDF construction
- + Open or closed impeller options
- + Powerful neodymium magnets
- + Close-coupled design
- + Threaded (NPT or BSP), union or flange connections
- + 1/8 inch impeller trims available
- + Vertical installation option with IEC motor
- + Mounts to NEMA and IEC (B5 and B14) motor frames
- + Replaceable shaft
- + ISO 1940 G2.5 balancing
- + CE certified/ATEX available
- + Working pressure up to 90 psi (6.2 bar)
- + Up to 1.8 SG
- + Viscosity up to 150 cP
- + Polypropylene—180° F (82° C)
- + PVDF—220° F (104° C)

APPLICATIONS

- + Chemical processing
- + Plating
- + Water and wastewater
- + Electronics
- + Pharmaceuticals
- + Wet scrubber
- + Pulp and paper
- + Heat exchanger

Notes: Performance curves above are based on closed impellers. Contact the factory for performance based on open impellers. Maximum power @ 3450 RPM is 13 hp (9.7 kW). [Consult factory for applications above 10 hp (7.5 kW)]. At 2900 RPM, maximum power is 7.5 kW (10 hp).

Description	Polypropylene Models	PVDF Models
1 Impeller housing	Glass-fiber reinforced polypropylene	Carbon-fiber reinforced PVDF
1A Impeller housing thrust ring options	High-purity alumina ceramic, silicon carbide	
2 O-ring options	FKM, EPDM, Simriz®, Kalrez®	
3 Impeller	Glass-fiber reinforced polypropylene	Carbon-fiber reinforced PVDF
3A Impeller thrust washer options	Fluorosint®, silicon carbide	
4 Inner drive	Neodymium iron boron magnets encapsulated in unfilled polypropylene	Neodymium iron boron magnets encapsulated in unfilled PVDF
5 Bushing options	Carbon, PTFE, silicon carbide	
6 Shaft options	High-purity alumina ceramic, Hastelloy® C, silicon carbide	
7 Barrier	Glass-fiber reinforced polypropylene	Carbon-fiber reinforced PVDF
7A Barrier thrust ring	High-purity alumina ceramic	
8 Motor adapter	Ductile iron	
9 Outer drive magnet	Nickel-plated, neodymium iron boron magnets/steel	
10 Motor adapter sealing kit (NEMA only)	Buna N (std), FKM, EPDM	

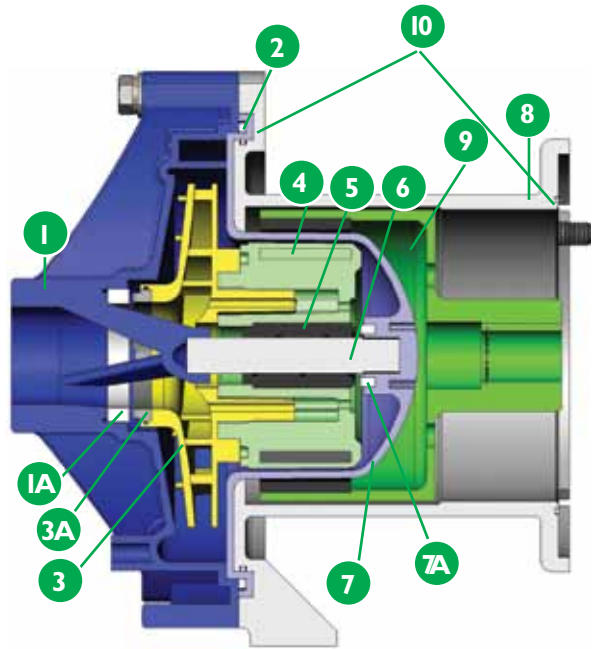

Kalrez® is a registered trademark of DuPont Performance Elastomers
 Simriz® Perfluoroelastomer is a registered trademark of the Simrit® division of Freudenberg-NOK
 Hastelloy® C is a registered trademark of Haynes International, Inc.
 Fluorosint® is a registered trademark of Quadrant Engineering Plastics.

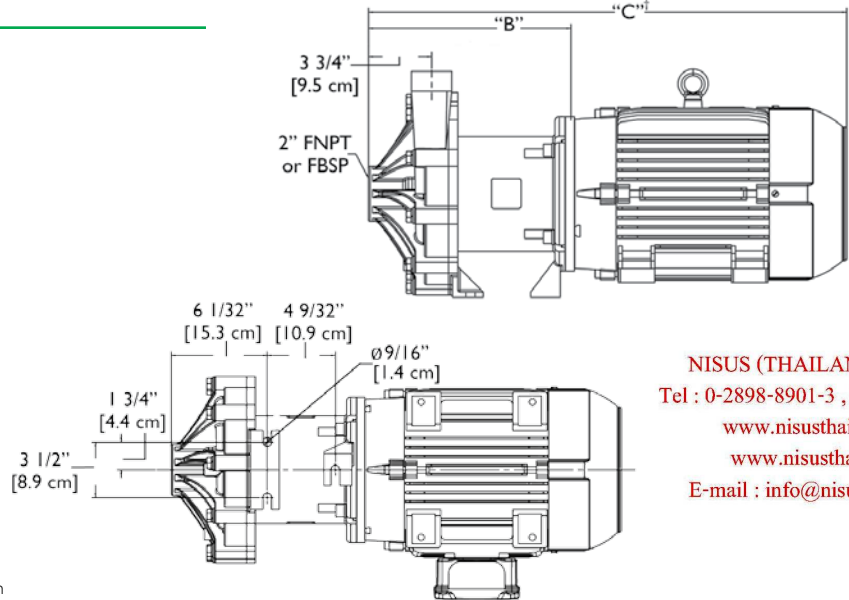
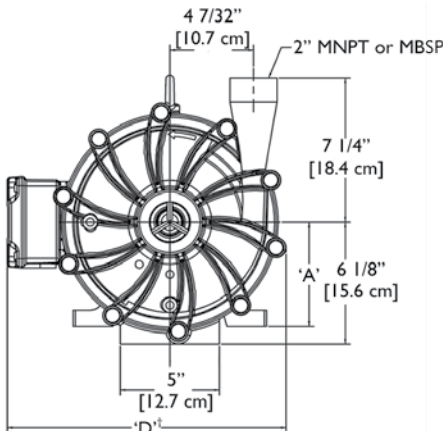

Also available 2" x 2" 150 lb. ANSI-ISO PN20/PN40 flange, 3" x 2" ANSI20 flange or 63 mm x 63 mm union connection

NISUS (THAILAND) CO., LTD.
 Tel : 0-2898-8901-3 , Fax : 0-2898-7745
www.nisusthailand.co.th
www.nisusthailand.com
 E-mail : info@nisusthailand.co.th

Motor Frame	A	B	C [†]	D [†]	Weight - lbs. [kg]	
					PP	PVDF
NEMA 184TC	4-1/2" [11.4 cm]	11-13/32" [29.0 cm]	26-7/16" [67.2 cm]	12-15/32" [31.7 cm]	40 [18.1]	44 [20.0]
NEMA 213/215TC	5-1/4" [13.3 cm]	12" [30.5 cm]	28-5/16" [71.9 cm]	14-1/32" [35.7 cm]	45 [20.4]	49 [22.2]
IEC 90 w/B14 or B5	3-17/32" [9.0 cm]	12-5/16" [31.2 cm]	23-5/16" [59.2 cm]	11-11/16" [29.7 cm]	48 [21.8]	52 [23.6]
IEC 100 w/B14 or B5	3-15/16" [10.0 cm]	12-5/16" [31.2 cm]	24-23/32" [62.8 cm]	12-1/8" [30.8 cm]	48 [21.8]	52 [23.6]
IEC 112 w/B14 or B5	4-13/32" [11.2 cm]	12-5/16" [31.2 cm]	25-15/32" [64.7 cm]	12-1/8" [30.8 cm]	48 [21.8]	52 [23.6]
IEC 132 w/B14 or B5	5-3/16" [13.0 cm]	12-3/8" [31.4 cm]	28-15/32" [72.3 cm]	14-3/16" [36.0 cm]	51 [23.1]	55 [24.9]

Note: Contact factory for dimensions on flanged or union models. Dimensions and weights are for reference only.
[†]Varies with motor manufacturer

